

General Electric Co.

Model: 260

Chassis:

Year: Pre 1948

Power:

Circuit:

IF:

Tubes:

Bands:

Resources

[Riders Volume 18 - CHANGES 18-3](#)

[Riders Volume 21 - CHANGES 21-3](#)

[Riders Volume 20 - CHANGES 20-5](#)

[Riders Volume 16 - GE 16-6](#)

[Riders Volume 16 - GE 16-7](#)

[Riders Volume 16 - GE 16-8](#)

[Riders Volume 16 - GE 16-9](#)

[Riders Volume 16 - GE 16-10](#)

[Riders Volume 16 - GE 16-11](#)

[Riders Volume 16 - GE 16-12](#)

[Riders Volume 16 - GE 16-13](#)

DeWald 418

This model is the same as model 414 appearing on page 11-2 of *Rider's Volume XI*.

Electronic Laboratories 2811

This model, shown on page 16-8 of *Rider's Volume XVI*, uses the Webster model 56 record changer, which is shown on page RCD.CH.15-10 of *Rider's Volume XV*.

Emerson BF-169, BF-204, And BF-207

These models are the same as Model BF-191 appearing on pages 9-1 and 9-2 of *Rider's Volume IX*.

Emerson 567, Chassis 120016

This model is the same as Model 560, Chassis 120016, appearing on pages 17-30 to 17-32 of *Rider's Volume XVII*.

FM Specialties Model Fidelotuner

This model is shown on pages 17-1 to 17-4 of *Rider's Volume XVII*. Three terminals are shown in Fig. 5, page 17-4; the first labelled 3, and the third terminal (not labelled in this figure) should be labelled 4. The ground from the phonograph connection to the receiver should be made to this third terminal (terminal 4).

Farnsworth AC-55, Chassis C2-3

This model is the same as model ACL-55, Chassis C 2-3, shown on pages 11-7 and 11-10 in *Rider's Volume XI*.

Farnsworth ACL 55, ACL56, AKL58, AKL 59

These models shown on pages 11-7 and 11-10 of *Rider's Volume XI* are erroneously listed as ATL.

Farnsworth GK-140

Slippage of the dial-drive cable on the early production sets can be corrected by replacing the cable with part number 05096. This cord is softer and smaller than the one used previously.

If the push buttons bind on the front panel of the cabinet, the ganged capacitor may not be properly positioned. This may be corrected by installing a flat metal washer under each of the mounting grommets. This may be done without removing the gang from the chassis.

Oscillation or low sensitivity on f.m. may be due to poor ground connections from the gang to the r-f shelf. When aligning the f-m band, oscillation may occur with certain signal generators. Changing the value of the resistor in series between the generator and the chassis will prevent oscillation. With some generators more than 400 ohms are required, with others less.

In some preliminary sets a 200- μ f capacitor was placed in series with the short-wave converter-trimmer. If

for any reason this trimmer requires replacement, removal of the capacitor is suggested. This capacitor is not shown on the schematic.

In some of the preliminary 14-tube sets, Belden braid was used to ground the ganged capacitor to the r-f shelf. In certain instances too much solder flowed into the braid and as a result some joints break loose or the set becomes microphonic. This braid should be replaced with soft copper strips.

General Electric A51, A56

These models are the same as model A54 shown on pages 7-4 to 7-6 of *Rider's Volume VII*.

General Electric H639AC-DC

The r-f alignment instructions of these models found on page 11-80 of *Rider's Volume XI*, should read as follows: With gang condenser plates completely meshed, set dial to the first mark at the left end of scale. Then set dial to 1500 kc. Apply a 1500-kc signal either through a standard I.R.E. dummy to the antenna terminal or through an additional loop connected to the generator output which can be magnetically coupled to the receiver Beam-Scope. Align C2 and C1 at 1500 kc for maximum output. Set dial to 580 kc and peak C3 on 580 kc while rocking the gang condenser. Retrim at 1500 kc.

GE YRB 60-12

This receiver is the same electrically as the YRB 60-2 appearing on page 15-5 of *Rider's Volume XV* but the cabinet is different.

GE YRB 92-2 and 81-3

These models are the same electrically as the YRB 82-1 appearing on pages 15-53 to 15-54 of *Rider's Volume XV*, but they have different cabinets.

General Electric L604

This model is the same as Model L600 appearing on page 13-40 of *Rider's Volume XIII*.

General Electric 202

This receiver is the same electrically as the model 200 as shown on pages 15-54 to 15-56 in *Rider's Volume XV*, except that it has a different cabinet.

General Electric 219, 220, 221

A few cases of hum which cannot be reduced in the normal manner from these models shown on pages 15-28 to 15-31 of *Rider's Volume XV*, may be corrected by cathode degeneration in the output tube, 35L6GT/G, cathode circuit. Remove R17 and C29-C from the circuit. This can be done by disconnecting one end of R17.

General Electric 260

This model appears on pages 16-7 to 16-12 of *Rider's Volume XVI*. It has been found that late production 1LC6 tubes, coded H7E, will oscillate at another frequency in addition to the desired frequency, causing unsatisfactory operation. To remedy this condition, the oscillator grid capacitor, C17, should be changed from 100 μ f to 56 μ f.

GE 254

This model is illustrated on pages 16-3 to 16-5 of *Rider's Volume XVI*. The suffix letters after 254 indicate only the cabinet styling. All versions are electrically identical.

Firestone 7402-4

This model is the same as model S7426-6 shown on page 10-5 of *Rider's Volume X*.

Firestone 7423-5

This model is the same as model S7402-5 shown on page 13-38 of *Rider's Volume XIII*.

Goodrich R655W

This model uses the Admiral record-changer model RC161 or RC161A, which are to be found on Admiral RCD. CH. pages 17-1 to 17-7 of Volume XVII.

Hallicrafters S-40A

This model is the same as Model S-40, second revision, on pages 16-67 to 16-86 of *Rider's Volume XV*, except for the following changes. C18 has been changed in value from 100 μ f to 68 μ f. A 10-ohm resistor (R30) has been connected between the center tap of oscillator coil T10 and terminal C. R30 has been removed from its previous position between C16 and the junction of C26, C6C, C7C, and switch S1F. C55 has been changed in value from 100 μ f to 47 μ f, and is now connected to the top of the 470- μ f capacitor (C54). The coil T17 is connected directly across C54, with one end going to ground. The center tap of this coil is connected to the cathode of the 6J8 tube. The 0.01- μ f capacitor (C53) is connected from the plate of the 6J8 tube directly to ground.

The parts list should be changed to read as follows:

Ref. No.	Description	Hallicrafter's Part No.
C18	68 μ f, \pm 10%, 500 vdcw; neg. temp. coeff.	CC25UK680K ceramic
C55	47 μ f, \pm 20%, 500VDC, Mica	CM20A470M
T17	BF0 coil; 455 kc; shielded	54B033-2

Hallicrafters SP-44 AND SX-42

These models appear on pages 17-1 to 17-5 and 17-6 to 17-16 respectively of *Rider's Volume XVII*. When the SX-42 is used with the SP-44 Panadaptor on the low-frequency band, it appears to motor boat. To correct this condition, do the following.

The connecting cable between the SP-44 and the SX-42 is shielded and the shield is connected to the SX-42 ground. Disconnect the shield from the SX-42 ground and place a 50- μ f capacitor between the shield and the SX-42 chassis. Be sure that the SX-42 chassis is well grounded. A shielded antenna lead, or a balanced antenna, on the SX-42 may also help.

The following modifications should be made on the SP-44 unit. A strip of bonding braid, $\frac{3}{8}$ inch wide, may

General Electric 143

The connection between terminal number 4 of the 2nd i-f transformer to the 8,200-ohm resistor R2 is connected at the intersection with the B+ line. Late production receivers incorporate the following changes in order to improve the i-f stability. A 0.05- μ f, 200-volt paper capacitor has been added in parallel with resistor R9. This capacitor has a reference number of C16 and stock number UCC-045. Capacitor C5 has been changed to a 0.1- μ f, 200-volt capacitor, stock number UCC-050.

General Electric 145

The following parts have been added to provide replacement of the battery cover plate and assembly parts:

Ref. No.	Description
RAC-078	Cover, cover plate only
RHR-009	Rivet, "A" battery spring rivet
RHR-010	Rivet, "A" battery clip rivet
RHW-014	Washer, "A" battery spring washer
RII-027	Insulator, insulator strip
RMC-037	Clip, battery clip
RMS-189	Spring, "A" battery spring.

The following miscellaneous parts have been added. Most of these parts are required because of the addition of brown and white cabinets.

Ref. No.	Description
RAB-093	Cover, back cover (white)
RAB-094	Cover, back cover (brown)
RAC-063	Cover, loop cover (maroon) substitute for RAC-07
RAC-069	Cabinet, main body (brown) includes hinge
RAC-070	Cabinet, main body (white) includes hinge
RAC-071	Cover, front cover (white) includes hinge
RAC-072	Cover, front cover (brown) includes hinge
RAC-075	Cover, loop cover (white)
RAC-076	Cover, loop cover (brown)
RAI-007	Stop, cover stop
RDK-173	Knob, brown control knob
RHR-004	Rivet, tube socket rivet
RHY-009	Handle, cabinet handle
RSW-070	Switch, power, operates in conjunction with lid.

General Electric 226

This model appears on pages 20-27 through 20-29 of *Rider's Manual Volume XX*. Resistor R1, tube V1 cathode resistor, was removed from the circuit of late production receivers. This change results in an increase of gain in the r-f amplifier.

Solid dots indicating circuit wiring connections should be added and placed in the cathode lead of tube V4, one at the point where the lead intersects the lower end of R7, the other at the junction of R6 (low end of volume control) and C10. The circuit will then show the cathode properly terminated to B+.

Replacement item RTO-075 should read RTO-083, Audio output transformer.

General Electric 250

This model appears on pages 15-32 through 15-36 of *Rider's Manual Volume XV*. With particularly rough handling, the battery may be cracked while in place in the battery compartment. To forestall this failure, an additional strip of sponge rubber may be installed at the bottom of the battery cover to give added padding. If the battery does not charge and the fuse checks o.k. and the rectifier disks are not defective, check continuity of the power cord. A few isolated cases have been found in which the power cord has opened up where the cord fastens to the prong in the molded plug. An appreciable increase in duration of operation from a fully charged battery can be effected in the following manner, realizing, however, that some degree of performance is sacrificed in regard to sensitivity and power output. Replace power-supply filter resistor R17 (1,500 ohms) with a 4,700-ohm, 1-watt, carbon resistor. This change should be made only when there is a demand for longer duration of operation to one battery charge.

General Electric 200 Series

These models appear on pages 18-19 through 18-20 of *Rider's Manual Volume XVIII*. The following changes should be added to the parts list:

RHM-002	Clip, for mounting speaker board
RHM-004	Clip, dial scale mounting clip for plastic cabinet models
RHM-005	Clip, dial scale mounting clip for wood cabinet models.

General Electric 250, 260

Model 250 appears on pages 15-32 through 15-36 of *Rider's Manual Volume XV*. Model 260 appears on pages 16-6 through 16-12 of *Rider's Manual Volume XVI*. Add REC-003, Antenna loop connector strip to the parts lists for these models.

General Electric 356

This model appears on pages 18-40 through 18-44 of *Rider's Manual Volume XVIII*. Resistor R12 has been changed from 220 ohms, 1/2 w, to 330 ohms, 1/2 w, \pm 10%, Cat. No. URD-037.

B. F. Goodrich 92-527, 92-528

These models are the same as Models 92-523, 92-524, 92-525, 92-526.

B. F. Goodrich 93-109, 93-110, 93-111

These models are the same as Models 93-104, 93-105, 93-106.

B. F. Goodrich 93-112, 93-113

These models are the same as Models 93-107 and 93-108.

Hoffman C503 and C513, Ch. 115

These models are identical with Models B503 and B513, which appear on pages 17-8 through 17-13 of *Rider's Manual Volume XVII*, except for the following changes:

1. Push-pull parallel 6K6's are used in the output stage instead of push-pull 6V6's. This is shown in the accompanying diagram.

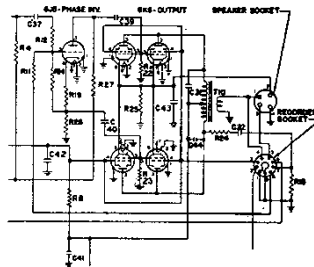

Circuit changes for Hoffman C503 and C513.

2. On the recorder amplifier the screen dropping resistor R11 has been changed from 0.1 megohm to 2.2 megohms. The cathode resistor, R1, for this stage has been changed from 2,200 ohms to 4,700 ohms. This allows the screen current of the 6SJ7 tube to be self-regulating and to eliminate variations in gain between various 6SJ7's.
3. R31 and C49 have been added in parallel to the S1-sec 2, rear, wafer lead that goes to the phonograph receptacle.
4. Capacitor C30 is now connected to the variable resistor, R20, instead of to ground.

Magnavox AMP-101B

This model is the same as Model AMP-101A which appears on pages 17-1 and 17-2 of *Rider's Manual Volume XVII*, except for the following change in parts values.

Ref. Part No. No.	Description
5	250129G4 Capacitor, paper, 0.03 μ f, 400 v.

Montgomery Ward 04WG-672 Series

Model 04WG-672 appears on pages 12-31 and 12-32 of *Rider's Manual Volume XII*. Models A and B are the same as that model which appears in Volume XII. Models C, D, and E are similar to Model 04WG-672 with the following exceptions. Model C employs a plug-in resistor, R13 and R12. The values remain the same as in the earlier models. Model D employs the plug-in resistor and, in addition, a new oscillator coil and 2 section dry electrolytic capacitor. In Model E the loop antenna assembly has been redesigned.

Montgomery Ward 05WG-2745A

This model is the same as Model 94WG-2745A. To reduce regeneration in later production receivers, the following changes were made:

Ref. No.	Part No.	Description
L-1	35A5	Insulated choke
C-6	47X496	500 μ mf ceramic capacitor
R-37	B84562	Added 5,600-ohm, 0.5-w carbon resistor. This resistor replaces the insulated choke L-5 in the circuit diagram.

Montgomery Ward 14WG-518A, 14WG-519A, 14WG-518B, 14WG-519B

These models are similar to Model 14WG-518 and 14WG-519 which appear on page 13-46 of *Rider's Manual Volume XIII*.

Montgomery Ward 64WG-2007B, 74WG-2007B and C

These models are similar to 54WG-2007A shown on pages 15-28 to 15-30 of *Rider's Volume XV*, except for the following changes. The drive-cord length has been increased and the following drive-cord replacement instructions are to be used.

Turn the gang condenser to the fully closed position. Use a new drive cord 18 inches in length and tie one end to the tension spring. Fasten the other end of the tension spring to the hook on the drive pulley. Pass the cord through the slot in the drive pulley rim and continue around pulley 1/2 turn, counterclockwise. Wind 3 1/2 turns counterclockwise (from front of chassis) around tuning shaft. Turns should progress toward rear of chassis. Wind cord counterclockwise around drive pulley in back of previous 1/2 turn. Pass cord through the slot in the pulley rim. Stretch tension spring and tie free end of cord to the spring. Cut off any excess string.

The component parts are the same as those listed on page 15-29 of *Rider's Volume XV*, except for those listed below.

Ref. No.	Part No.	Description
C-15	B67204	0.20 μ f, 200 v, tubular
C-16	D67104	0.10 μ f, 400 v, tubular
C-18	D67102	0.001 μ f, 400 v, tubular
C-19	17A123	1.0-12 μ f, trimmer.

GE 210, 211, 212

These models appear in *Rider's Volume XVIII*, pages 18-21 through 18-25. In the schematic diagram C12 is shown as 22 μf . This should be corrected to read 20 μf . C12 is listed correctly in the replacement parts list as Cat. No. RCW-3016, 20 μf .

The following items should be added to the replacement parts list:

R11-021—Insulator — Textolite (to insulate the volume control from chassis)

R11-022—Insulator — Textolite (to insulate the band switch from chassis)

In the tube and trimmer location shown on page 18-25, the secondary tuning slug of T6 is available through the top of the can, while the primary tuning slug of T6 is available through the holes in the bottom of the can.

General Electric 219, 220, 221

These models appear on pages 15-28 through 15-31 of *Rider's Volume XV*. In the parts list, catalog number RLL-003 should be identified as a replacement loop assembly only for Models 219 and 220. Catalog number RLL-025 should be added as the loop assembly for Model 221.

General Electric 250, 260

Model 250 appears on pages 15-32 through 15-36 of *Rider's Volume XV*. Model 260 appears on pages 16-6 through 16-12 of *Rider's Volume XVI*. The following should be added to the parts list for both models: Hinge pin for cover, catalog number RMP-011.

General Electric 321A

This model is the same as Model 321 Late, appearing on pages 15-46 and 15-52 of *Rider's Volume XV*.

General Electric 356, 357, 358

These models appear on pages 18-40 through 18-44 of *Rider's Volume XVIII*. The following changes should be made in the parts list. Under UCC-025, remove symbols C43, C65, C70. Add to UCC-026 symbols C43, C65, C70.

General Electric 356, 357, 358; 376, 377, 378

Models 356, 357, and 358 appear on pages 18-40 through 18-44 of *Rider's Volume XVIII*. Models 376, 377, and 378 appear on pages 19-36 through 19-41 of *Rider's Volume XIX*. When an old type construction 6BE6 (date coded 8/17 or before) is replaced with a new type construction 6BE6 (dated 8/22 or later) it is necessary that the f-m oscillator choke coil L8 be a 13½-turn coil (catalogue number RLF-012) instead of the 17-turn coil that was used in early production models.

General Electric 376, 377, 378

These models appear on pages 19-36 through 19-41 of *Rider's Volume XIX*. The f-m choke, L8, in the cathode circuit of the 6BE6 oscillator converter tube, V2, was listed under catalog number RLF-007. Due to a production change, this choke now becomes RLF-012.

Delete URD-633, R12, Resistor—220 ohms, ½ w., carbon. Add URD-037, R12, Resistor—330 ohms, ½ w., carbon. Add RCW-3009, C37, Capacitor—20.5 μf , $\pm 5\%$, ceramic. Delete UCW-2011, C37, Capacitor—20 μf , ceramic. Add symbol number P4 to RJP-003. Delete P3 and P4 (Plug—preamplifier power plug) from RJP-004. Add RJP-005, P3, Plug—preamplifier power plug.

General Electric 417, 417A

Model 417 appears on pages 16-16 through 16-19, and pages 16-31 through 16-34 of *Rider's Volume XVI*. Model 417A appears on pages 17-21, 28 through 17-38 of *Rider's Volume XVII*. These changes are in reference to the wiring of Phono Preamp Plug RJP-005.

Since some of the plugs supplied are inconsistent with specifications regarding the identification notch often referred to in wiring guides, this notch must be disregarded for identification purposes to avoid confusion. While in some receiver productions the position of this key notch will differ from others, nevertheless, all receiver productions are wired the same in respect to the polarized system of prong arrangement.

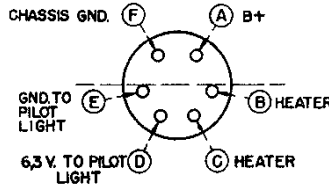

Phone Preamp Plug RJP-005 in the GE 417, 417A should be wired as shown.

When replacing the plug RJP-005, it is only necessary to follow the simple wiring rule as used in all receiver production where the cluster of four prongs is first located within one-half the area of the plug base as determined by the imaginary center line. Next, locate the two remaining prongs as viewed from the prong end of the plug and begin the wiring in a clockwise direction as indicated by the letter designations in the accompanying diagram. The letters A, B, C, etc., in the diagram, are keys to wiring points, as referred to in the various published receiver circuit diagrams.

Magnavox AMP-101C

This model is the same as Model AMP-101A on pages 17-1 and 17-2 of *Rider's Volume XVII*, except for the following changes in parts values.

Ref. No.	Description	Part No.
2-1	Capacitor, paper, 0.1 μf 600 v.	250152G33
2-2	Capacitor, paper, 0.1 μf , 600 v.	250152G33
8	Resistor, composition, 15,000 ohms, $\pm 10\%$, ½ w.	230084G76
9	Resistor, composition, 100,000 ohms, 10%, ½ w.	230084G86

Magnavox AMP 111D, AMP 111E

These models are the same as Model AMP 111, appearing in *Rider's Volume XVIII*, pages 18-4 through 18-7, except for the following parts value changes:

Ref. No.	Description	Part No.
9	Capacitor, paper, 0.03 μf , 400 V	250152G25
22	Resistor, composition, 22,000 ohms, $\pm 10\%$, ½ W	230084G78

Hoffman C501 and C511. Chassis 108

These models are the same as Model A501, Ch. 108S, appearing on pages 15-6 through 15-10 of *Rider's Manual Volume XV*, except that four 6K6 beam-power tubes are used in push-pull parallel in the output stage instead of the two push-pull 6V6's. The change is indicated in the accompanying diagrams. The alignment is still the same as given on page 15-9.

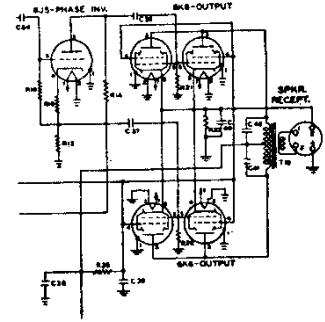

6K6 tubes for Hoffman C501 and C511.

The parts list should be changed to read as follows:

Symbol	Description	Hoffman Number
C47, C23, C24	100 μf , $\pm 20\%$, mica	4000
C25		
C28, C32	0.005 μf , 600 volt, tubular paper	4102
C29, C30	10 μf , 450 volt, tubular electrolytic	4203
C31, C33, C34	0.01 μf , 400 volt, tubular paper	4112
C41, C46	0.001 μf , 600 volt, tubular paper	4104
C43	0.01 μf , 600 volt, tubular ceramic	4103
C42, C44	330 μf , $\pm 10\%$, mica or ceramic	4010
C45	650 μf , $\pm 10\%$, mica or ceramic	4011
L1	Loop antenna	55210
LS	12" speaker, electrodynamic	9044
R2, R17	22,000 ohm, $\pm 20\%$, ½ w	4501
R3, R27	2.2 megohm, $\pm 20\%$, ½ w	4502
R4	10,000 ohm, $\pm 10\%$, 2 w	4503
R11	4,700 ohm, $\pm 20\%$, ½ w	4543
R12, R18	47,000 ohm, $\pm 20\%$, ½ w	4543
R23	500 ohm, $\pm 20\%$, 3 w	4550
R28	1,500 ohm, $\pm 5\%$, 6 ½ w	4701
R13, R14, R24	47,000 ohm, $\pm 5\%$, ½ w	4537
R25		
R26	22,000 ohm, $\pm 5\%$, ½ w	4538
T10	Output transformer	5108

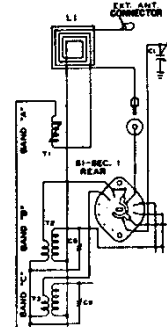

Antenna connection changes for Hoffman C501 and C511.

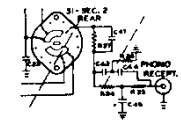

Circuit changes for Hoffman C501 and C511.

Ketay RP570T

This model appears in the *Miscellaneous section*, page 15-8 of *Rider's Manual Volume XV*. This model is listed in the Indexes as RP507T. It should read RP570T.

16-7.8

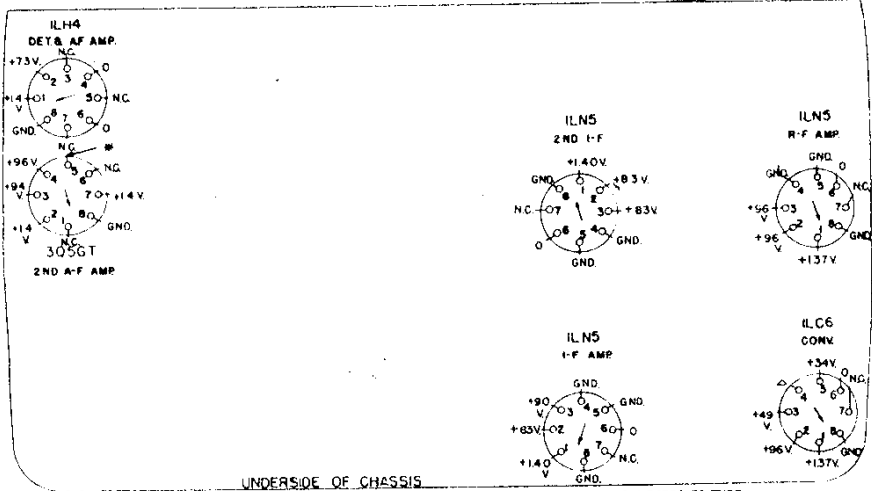
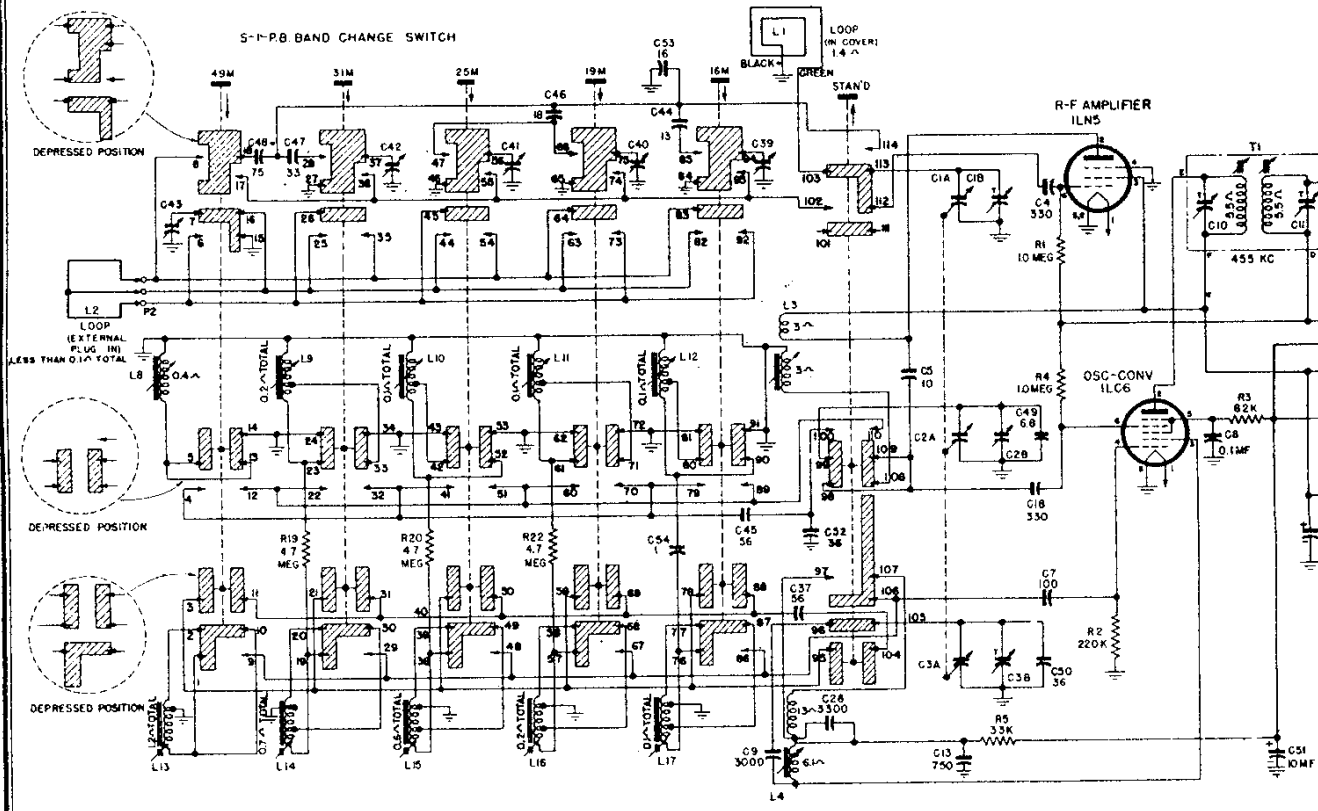

CONDITIONS OF TEST:
 ALL MEASUREMENTS D-C
 MEASUREMENTS MADE TO GROUND
 MEASUREMENTS MADE WITH 20000 OHM/VOLT METER
 LINE VOLTAGE 117-V BATTERY FULLY CHARGED
 VOL CONTROL MAX CLOCKWISE
 TONE CONTROL TREBLE POSITION
 RECEIVER OPERATING ON BROADCAST BAND

NC - NOT CONNECTED TO TUBE
 * - 45V IF MEASURED WITH VTVM
 CENTER POST ON ALL LOGCAL TUBES IS GROUNDED
 Δ READING AFFECTED BY INSTRUMENT

Socket Voltage Diagram

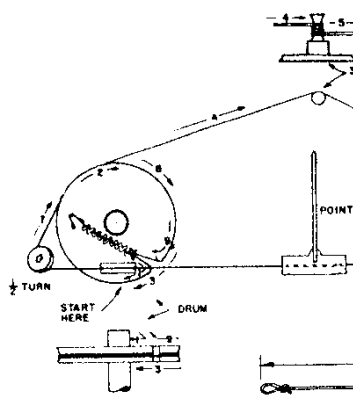

Dial Stringing

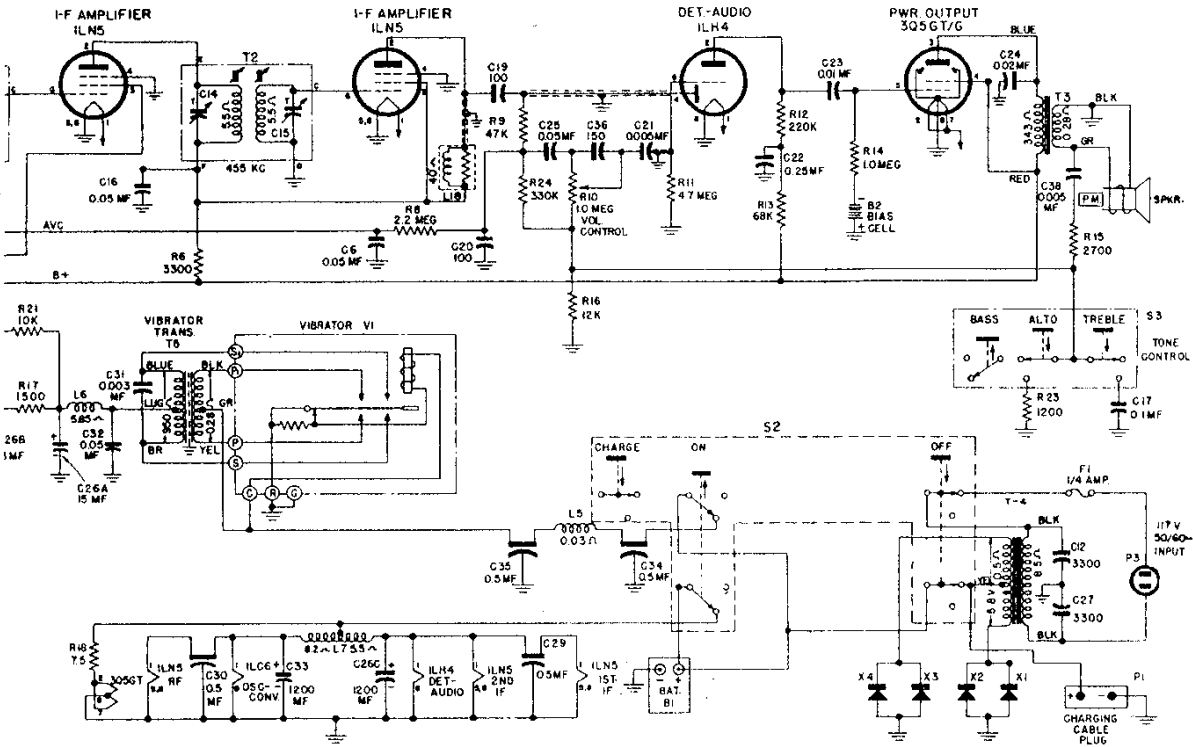

TURN ON TUNING SHAFT

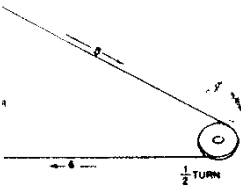

CORD LENGTH

Diagram

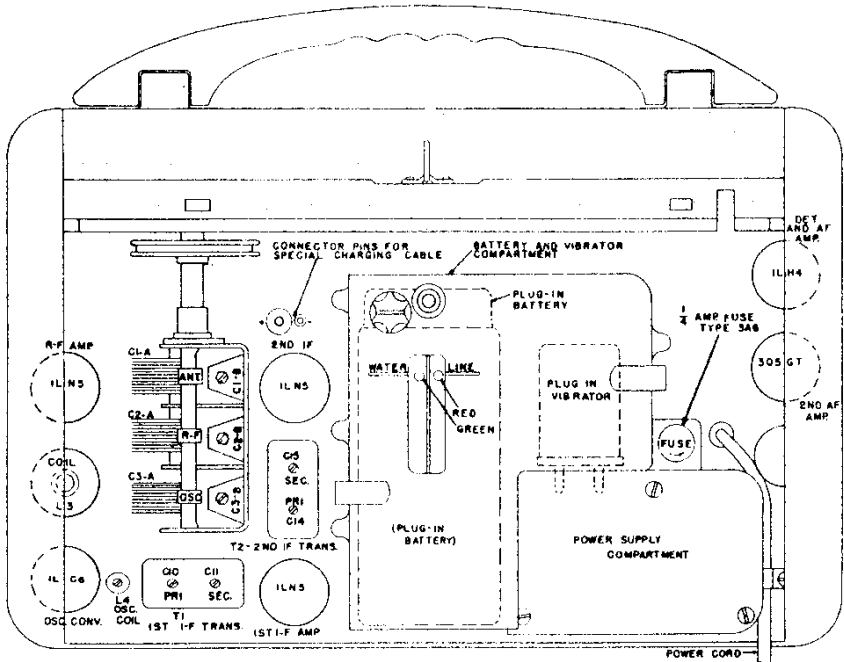

Tube and Trimmer Location

GENERAL ELECTRIC CO.

MODEL 260

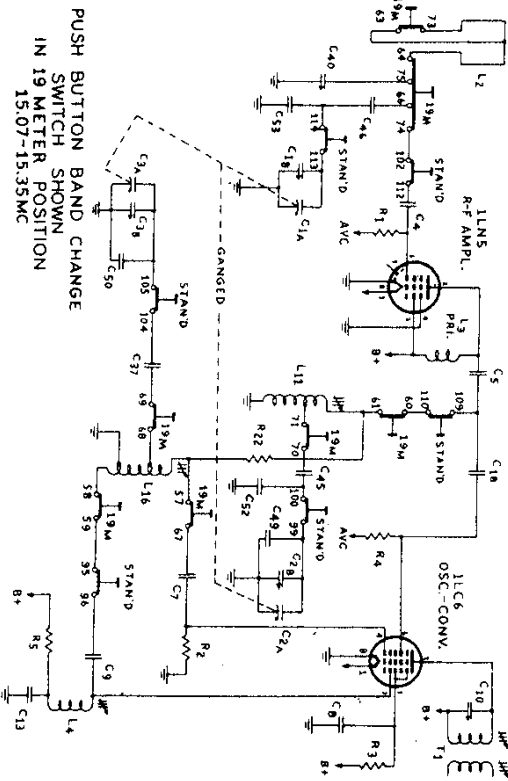
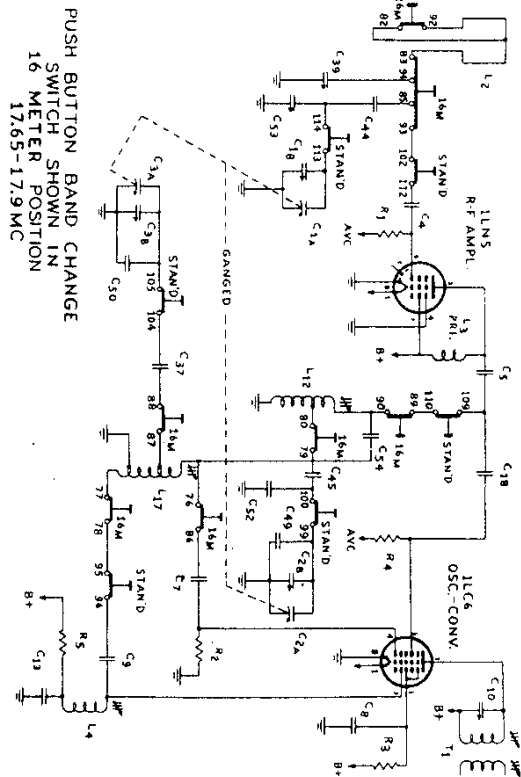
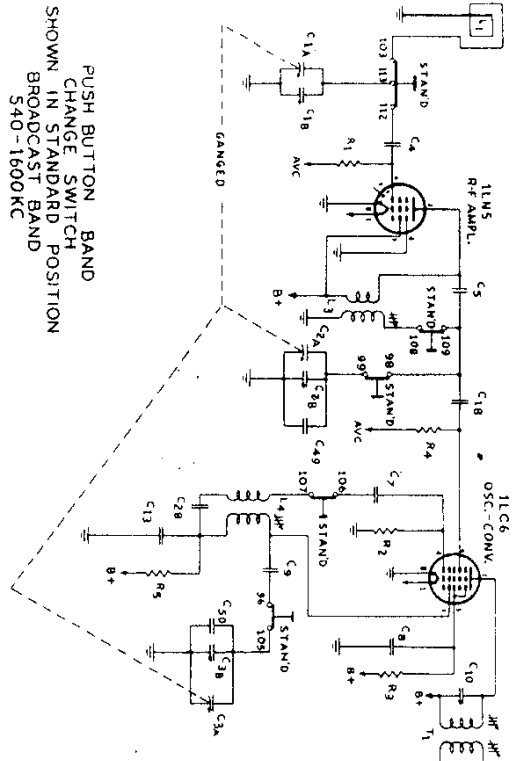

GENERAL ELECTRIC CO.

MODEL 260

ELECTRICAL CIRCUIT ALIGNMENT

1. EQUIPMENT REQUIRED.

1. Signal Generator with Audio Tone Modulation.
2. A-c output meter, 1 or $1\frac{1}{2}$ volts full scale, 1000 ohms/volt.
3. Insulated screwdriver.

2. ALIGNMENT PROCEDURE.

1. **General.**—The alignment procedure is given in table form for convenience. Reference is made to Figures 3, 5, and 6 for the trimmer locations. The low side of the signal generator should be connected to the chassis of the receiver for i-f alignment; the high side should be connected as indicated in the Alignment Chart. A meter or some other suitable indicating device must be connected to the output of the receiver. Two methods for connecting an output meter are given in later paragraphs.

When aligning the receiver, the Volume Control on the receiver should be turned to its maximum position and the TREBLE push button should be depressed. The output signal of the signal generator should be kept as low as possible at all times; the reading of a meter connected across the voice coil leads of the receiver should be kept below $\frac{1}{2}$ volt by changing the signal generator output. If the signal level is too high, the AVC becomes effective and alignment errors may result.

The following paragraphs give greater details regarding the connection of the output meter and the signal generator to the receiver during alignment.

2. **Connecting the Output Meter.**—In aligning the receiver, some means for indicating differences in the output voltage will be required. Either of the following methods is satisfactory. The first requires more disassembly of the receiver case than the second, but the second requires additional test equipment.

Method 1.—A satisfactory method for indicating differences in output is to connect a rectifier-type a-c meter of 1 or $1\frac{1}{2}$ volts full scale deflection across the speaker voice coil terminals. To gain access to the speaker, remove the front panel from the radio as previously described. Connect a lead to the green lead that connects to the ungrounded side of the speaker voice coil. Thread this lead through into the rear compartment. The front panel is reinstalled in place so that the stray capacities in the set will be the same as when the set is operating normally. Connect the meter between this lead and ground. A convenient ground connection may be obtained by removing the push-button band change switch escutcheon, and connecting a clip lead to the exposed chassis.

STAGE GAINS AND VOLTAGE CHECKS

Stage gain measurements may be made with a vacuum tube voltmeter to check circuit performance and to locate stages which are not operating properly. The gain values listed may have a tolerance of 20%.

1. R-F and I-F Stage Gains.

- R-F amplifier grid (6) to converter grid (6)..... 8.0 at 1000 kc
 R-F amplifier grid (6) to converter grid (6)..... 6.0 at 6100 and 9600 kc
 R-F amplifier grid (6) to converter grid (6)..... 5.0 at 11.8, 15.2 and 17.8 mc
 Converter grid (6) to 1st IF grid (6)..... 26 at 455 kc
 Converter grid (6) to 1st IF grid (6)..... 15 at 1000 kc
 Converter grid (6) to 1st IF grid (6)..... 15 at 6100 kc, 9600 kc, 11.8 mc, 15.2 mc, and 17.8 mc
 1st IF grid (6) to 2nd IF grid (6)..... 69 at 455 kc
 2nd IF grid (6) to diode plates..... 3.9 at 455 kc

2. Audio Gain.

The power output across the speaker voice coil should be approximately 50 milliwatts with a 400 cps audio signal of 0.07 volts applied across the volume control, R10 (volume control maximum—TREBLE push button depressed).

3. Oscillator Grid Bias.

The d-c voltage developed across the oscillator grid leak (R2) averages 6.5 volts at 1000 kc.

Method 2.—The following is an alternate method which eliminates the necessity of removing the front panel of the set, but which requires additional test equipment. Make an indicating device by connecting a 4- to 6-inch diameter magnetic speaker or the high-impedance leads from the output transformer of a good p-m dynamic speaker to the terminals of a rectifier-type microammeter with a full scale deflection of 100 microamperes or less. For convenience, the meter and speaker may be mounted in a small box in such a way that the meter will be visible when the speaker is placed in front of the speaker on the receiver being aligned.

To use this device, place its speaker in front of and about an inch away from the speaker of the receiver being aligned. The meter will then deflect in proportion to the intensity of the sound produced by the speaker, and therefore may be used as an output meter. The meter must not be moved during alignment.

3. **Connecting the Signal Generator.**—For aligning the i-f transformers, the output of the signal generator should be coupled through a 0.05 mf. capacitor to the grid (pin 6) of the 1LC6 oscillator-converter tube. This may be accomplished easily by connecting the capacitor to the stator of C2-A, the middle section of the tuning gang, as this stator is connected to the converter grid through a blocking condenser. The low side of the signal generator output should be connected to the chassis ground to complete the circuit.

For aligning the oscillator, r-f, and loop circuits, the r-f signal should be inductively coupled by means of a three- or four-turn, 6-inch diameter, loop of bell wire across the signal generator output terminals. The loop should be located about one foot from the radio cover, with cover open for broadcast alignment, and about one foot away from the external loop when making the shortwave band alignment. To prevent possible errors in peak-readings, the position of the loop with respect to the receiver should not be changed during any one set of adjustments.

4. **Alignment Suggestions.**—The dial pointer should fall under the extreme left end mark on the dial scale when the gang condenser is fully closed. If necessary, move the dial pointer along the dial drive cord until such registration is obtained.

To gain access to the shortwave oscillator tuning slugs, L13 through L17, remove the snap cover from the bottom of the receiver. The short-wave antenna and converter trimmers are accessible when the push-button band-change switch escutcheon (right-hand side) is removed. When aligning the trimmers on the gang condenser (for broadcast band alignment), close the cabinet back cover and make the adjustments through the snap button openings in the back cover.

The oscillator operates on the high frequency side of the signal on all bands. With this method of operation, and with the dial set at an alignment point, the image response should be heard when the signal generator is tuned to a frequency 910 kc. higher than the alignment frequency.

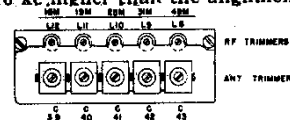

Fig. 5. RF and Antenna Trimmer Location

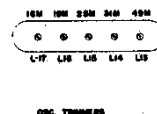

Fig. 6. Oscillator Trimmer Location

MODEL 260

GENERAL ELECTRIC CO.

ALIGNMENT CHART
 Depress Treble Push Button
 Turn Volume Control to Maximum

Step	Sig. Gen. Setting	Connect Signal Generator to	Depress Push Button	Dial Scale Setting	Adjust
1	455 kc	Stator of C-2A in series with .05 mf	Standard	Below 550 kc	2nd i-f (T2) trimmers for max.
2	455 kc	Stator of C-2A in series with .05 mf	Standard	Below 550 kc	1st i-f (T1) trimmers for max.
3	1500 kc	Inductively coupled	Standard	1500 kc	**C-3B, C-2B, and C-1B for max. in sequence given
4	580 kc	Inductively coupled	Standard	580 kc	* L4 and L3 for max.
5	R e p e a t S t e p 3				
6	6.1 mc	Inductively coupled	49 M	6.1 mc	L13 for max.
7	6.1 mc	Inductively coupled	49 M	6.1 mc	* L8 and C43 for max.
8	9.6 mc	Inductively coupled	31 M	9.6 mc	L14 for max.
9	9.6 mc	Inductively coupled	31 M	9.6 mc	* L9 and C42 for max.
10	11.8 mc	Inductively coupled	25 M	11.8 mc	L15 for max.
11	11.8 mc	Inductively coupled	25 M	11.8 mc	* L10 and C41 for max.
12	15.22 mc	Inductively coupled	19 M	15.22 mc	L16 for max.
13	15.22 mc	Inductively coupled	19 M	15.22 mc	* L11 and C40 for max.
14	17.8 mc	Inductively coupled	16 M	17.8 mc	L17 for max.
15	17.8 mc	Inductively coupled	16 M	17.8 mc	* L12 and C39 for max.

* Alternately peak circuits to obtain peak while rocking gang condenser.

** Remove snap buttons on back cover to permit these adjustments and close back cover while aligning.

NOTE.—The oscillator operates on the high frequency side of the signal on all bands.

BATTERY INFORMATION

The receiver uses a 2-volt Willard Radio Battery No. 25-2 or equivalent. It has a 25 ampere-hour capacity and should be cared for in the same manner as any other storage battery.

Charge Indicator

The degree of charge of the battery can be determined by raising the back cover of the radio and referring to the charge ball indicators visible through the hole in the metal battery case.

If the battery is fully charged, two indicator balls will be visible at the surface of the liquid in the battery. When the battery discharges, these ball indicators will sink and disappear in the following order:

1. Green indicator sinks when approximately 20 per cent of battery capacity has been discharged.
2. The red ball sinks when battery is 80 per cent discharged.

On charge, the balls rise or float in the reverse order and the charge may be stopped when both balls appear in the opening.

To Charge Battery

The battery is charged by merely plugging the receiver power cord in the rated a-c power outlet and depressing the CHARGE push button. Frequent check should be made of the charge indicator and when both indicator balls are visible, the battery is adequately charged. Charging the battery after all indicator balls are visible will not harm the battery except that it will evaporate the water faster. A completely discharged battery will be restored usually within 20 to 30 hours.

When operating the receiver from the a-c house current, the battery floats or is being charged at a slow rate. Thus, if you wish to operate the receiver at the same time that you are charging even a fully discharged battery, plug the power cord in the a-c receptacle and depress the ON push button. Prolonged operation in this manner usually will cause the battery potential to stabilize at some voltage determined by the line voltage and the characteristics of the charging circuit components. The degree of charge obtainable with this method of operation likewise is dependent on the line voltage and the characteristics of the charging circuit components.

Battery Operating Instructions

1. Add distilled or tap water in the filler cap at sufficiently frequent intervals to keep liquid level at indicator mark as viewed through opening in battery case. DO NOT OVER-FILL as this impairs the nonspill feature.
2. Whenever possible, it is best not to allow the battery to become discharged to the extent that both indicators disappear.

However, if both indicators have sunk, the battery should be recharged immediately or within 24 hours.

3. A battery will continually discharge at a slow rate even when not in use. For this reason, monthly checks should be made of the charge condition, and the battery should be placed on charge when necessary. This will prevent damage to the battery such as freezing during cold weather.

BATTERY INSTALLATION

The following instructions should be carefully followed in installing a battery, or replacing an old one:

1. Remove new battery from packing carton.
2. If needed, add water to bring liquid level to indicator mark on battery container. Do not overfill.
3. Raise back cover on radio, remove battery case cover. The latter is removed by unclipping the two catches. Pry off cover.
4. Unplug old battery if present, and replace with new battery.
5. Place battery on charge, if necessary, as described in a previous paragraph, until both indicators are showing in the opening in the case cover.

