

MODEL L-915  
MODELS L-915W, L-916

GENERAL ELECTRIC CO.

Stock No.	Symbol	Description	List Price
*RQ-1323	R-37, 38	RESISTOR—470,000 ohm 1/2-W carbon	\$0.70-5
*RL-582	L-1	BEAM-A-SCOPE—"B" band loop assembly	3.25
*RL-1017	L-2	COIL—"C" band antenna coil	.20
*RL-583	L-3	BEAM-A-SCOPE—"D" band loop assembly	.45
*RL-372	L-4	CHOKE—RF interstage choke	.20
*RL-2067	L-5-6-7	COIL—"D" "C" and "B" bands oscillator coil	1.05
*RL-9598	L-8a, b, c, d, e	COIL—Station selector trimmer coil assembly	4.50
*RS-3131	S-1	SWITCH—Band change switch	1.35
*RS-3108	S-2	SWITCH—Bass-tone control switch	.20
*RS-3132	S-3a, b, and c	SWITCH—Push button switch (switch only)	1.80
*RT-3013	T-1	TRANSFORMER—1st I.F. transformer	1.20
*RT-3014	T-2	TRANSFORMER—2nd I.F. transformer	1.25
RT-4023	T-3	TRANSFORMER—Output transformer	1.50
RT-0911	T-4	TRANSFORMER—50-60 cycle power transformer	5.25
RS-1085	L-10	SPEAKER—14 inch dynamic speaker	6.50
RW-409	L-11 C-15	WAVE TRAP—Wave trap assembly	.50

MISCELLANEOUS PARTS

*RB-026	BOARD—Antenna terminal board	\$0.10
*RB-094	BOARD—7 lug terminal board	.10
*RB-096	BOARD—3 lug terminal board	.10
*RB-1030	BOARD—Phono terminal board	.10
*RB-1046	BOARD—3 lug terminal board	.10
*RC-863	CORD—Power cord	.75
*RC-1987	CLAMP—Oscillator coil clamp	.05-2
*RC-2015	CLAMP—Dial scale mtg. clamp	.10-5
*RC-2021	CORE—Station coil tuning core	.10

\* Used on previous receivers.

Cabinet Dimensions

Model	L915W	L916
Height	40 in.	40 in.
Width	29 1/4 in.	29 1/4 in.
Depth	13 3/8 in.	14 1/8 in.

Electrical Rating

Rating "A"—110-125 volts, a-c, 50-60 cycles, 100 watts.  
Rating "C"—110-125 volts, a-c, 25 cycles, 100 watts.

Tuning Frequency Range

"BC" Band	550-1700 KC
"SW1" Band	1.7-5.5 MC
"SW2" Band	5.5-18.0 MC

Intermediate Frequency

455 KC

Electrical Power Output

Undistorted	6 watts
Maximum	9 watts

Loudspeaker—Electrodynamic

Outside cone diameter	14 inches
Voice coil impedance (400 cycles)	5.0 ohms

Tubes

RF Amplifier	GE-6SG7
Converter-Oscillator	GE-6SA7
IF Amplifier	GE-6SK7
Detector, AVC & 1st Audio	GE-6SQ7
2nd Audio	GE-6J5GT
Phase Inverter	GE-6J5GT
Power Output	(2) GE-6V6GT
Rectifier	GE-5Y3G
Pilot Lamp	(2) MAZDA No. 44

GENERAL INFORMATION

Models L915W and L916 are electrically identical and only vary in cabinet and dial scale treatment.

In Model L915W, electrodynamic speaker RS1092 (marked K33J371) was substituted for a portion of the production in place of the speaker listed in the parts list (marked K-33J365). Since this substitute speaker has a field coil resistance of 400 ohms instead of 500 ohms as shown on the schematic diagram, a 100 ohm resistor, RQ621, is added in series with the speaker field coil to maintain proper socket

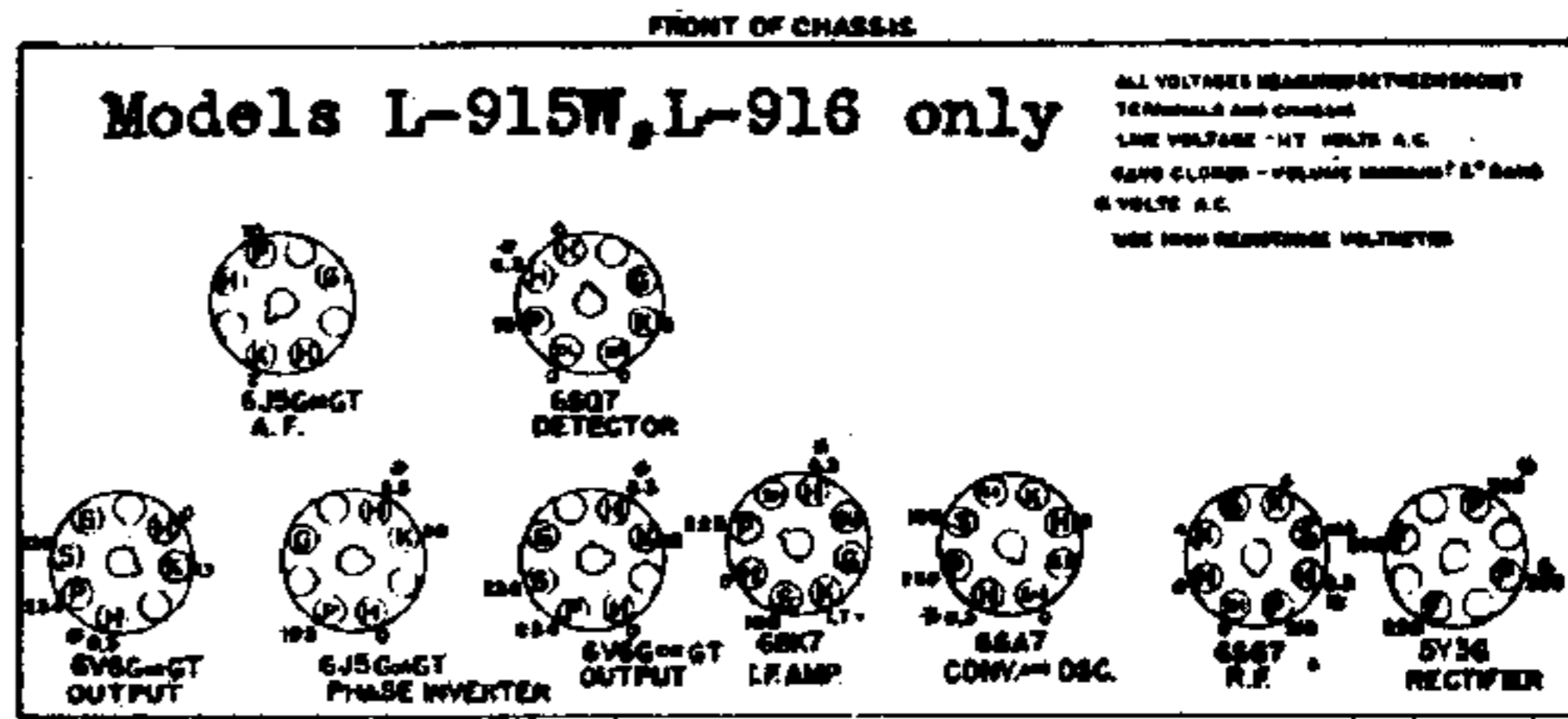

Fig. 3. Socket Voltages

voltages whenever this substitute speaker is used. When replacing the cone for either speaker, use Stock No. RC9045.

ALIGNMENT PROCEDURE

The location of all trimmers is shown in Fig. 4. All oscillator and RF trimmers are accessible from the back of the receiver.

The alignment procedure is given in table form. All IF alignment may be made with the chassis removed from the cabinet. However, the RF alignments are made with the chassis and loop antennas securely bolted in the cabinet, as the relative position of the loop antennas with respect to the chassis materially affects the alignment. The RF signal should be capacity coupled by placing a two-foot wire for an antenna on the test oscillator output post (high side). Keeping this antenna two feet or more from the receiver loop will generally assure freedom from too much coupling.

ALIGNMENT CHART

Step	Connect Test-Osc. To	Test Osc. Setting	Pointer Setting	Adjust Trimmers for Maximum Output
1	6SK7 IF grid in series with .05 mfd.	455 KC	"BC" Band 550 KC	C10 & C9
2	6SA7 converter grid in series with .05 mfd.	455 KC	"BC" Band 550 KC	C8 & C7
3	6SQ7 RF grid in series with .05 mfd.	455 KC	"BC" Band 550 KC	C15***
4	Capacity Coupled	580 KC	"BC" Band 580 KC	C25**
5	Capacity Coupled	1500 KC	"BC" Band 1500 KC	C24** (Osc.)
6	Repeat Step 4			
7	Capacity Coupled	5 MC	"SW1" Band 5.0 MC	C22** (Osc.)
8	Capacity Coupled	18 MC	"SW2" Band 18.0 MC	C19* (Osc.)
9	Capacity Coupled	18 MC	"SW2" Band 18.0 MC	C2** (Ant.)

\* Use minimum capacity peak.  
\*\* Rock gang condenser when making alignment.  
\*\*\* Peak for minimum output.

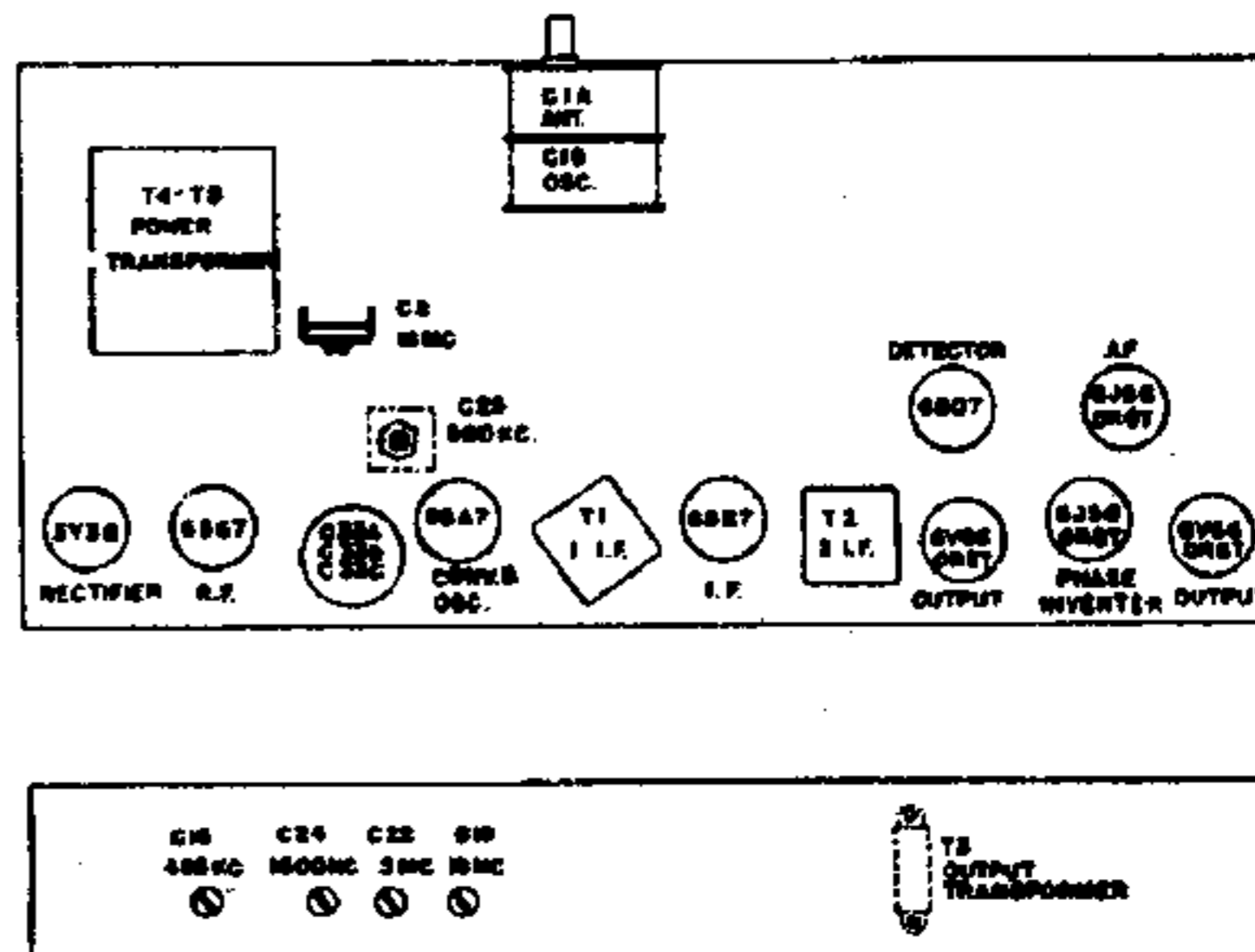

Fig. 4. Trimmer Location

GENERAL ELECTRIC CO.

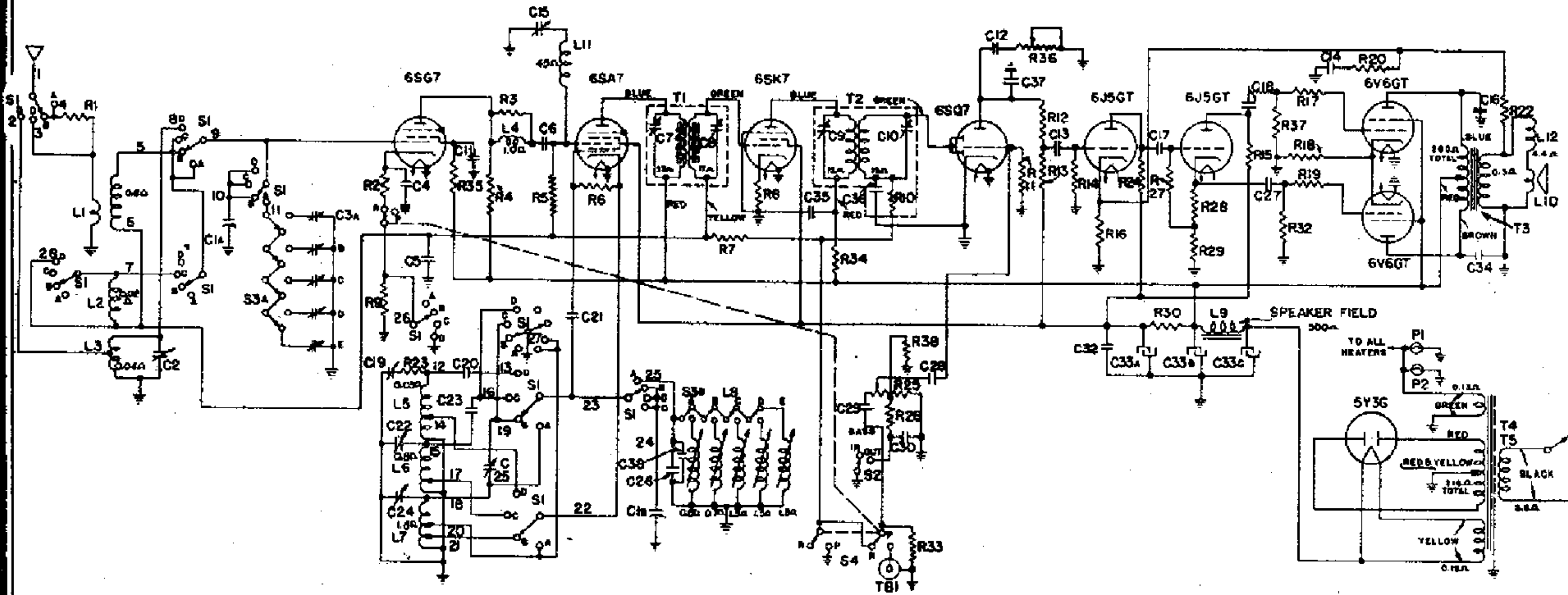
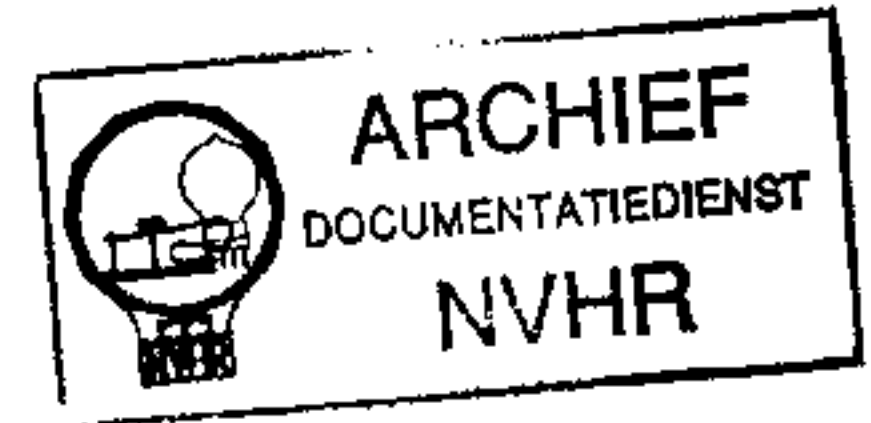
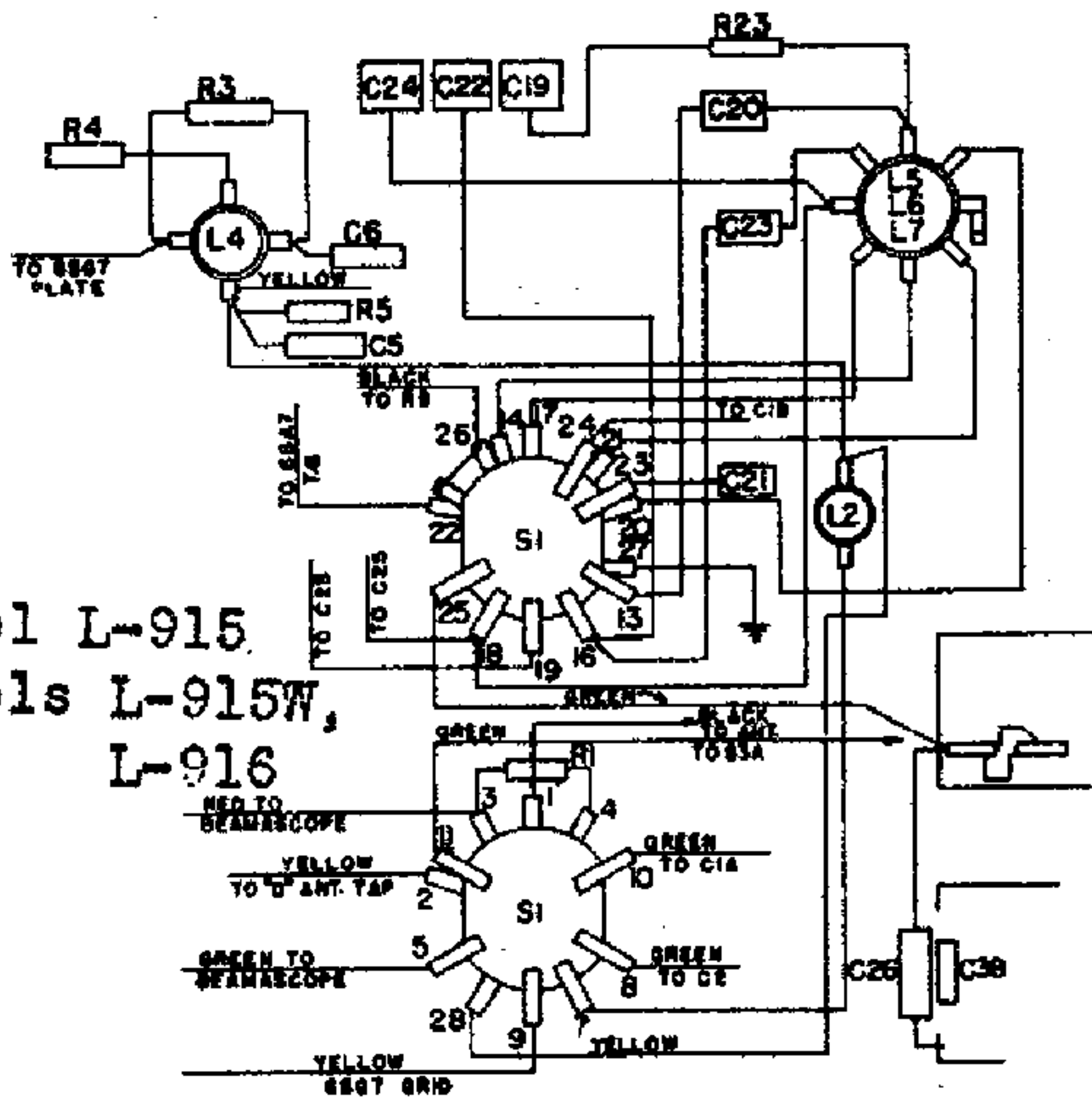

Fig. 1. Schematic Diagram

MODELS L-915W, L-916

IF 455 K.C.



Model L-915  
Models L-915W,  
L-916

Fig. 2. Switch Wiring

Stock No.	Symbol	Description	List Price
*RC-7063	C1a, 1b	CONDENSER—Tuning condenser...	\$2.00
*RC-6537	C2	CAPACITOR—"D" band trimmer...	.25
*RT-886	C-3a, b, c, d, e	TRIMMER STRIP—Station selector trimmer strip...	.95
*RC-092	C-4	CAPACITOR—.05 mfd. 600V paper...	.30
*RC-096	C-5	CAPACITOR—.01 mfd. 200-V paper...	.30
*RC-235	C-6	CAPACITOR—100 mmf. mica...	.25
*RC-048	C-11	CAPACITOR—.02 mfd. 600-V paper...	.30
*RC-023	C-12	CAPACITOR—.005 mfd. 600-V paper...	.25
*RC-048	C-13, 14	CAPACITOR—.02 mfd. 600-V paper...	.30
*RC-191	C-16	CAPACITOR—.002 mfd. 1000-V paper...	.35
*RC-060	C-17, 18	CAPACITOR—.03 mfd. 600-V paper...	.25
*RT-887	C-19	TRIMMER STRIP—"D" band osc. trimmer (Part of C-22, 24)...	.40
*RC-396	C-20	CAPACITOR—5600 mmf., mica...	.45
*RC-216	C-21	CAPACITOR—47 mmf. mica...	.25
*RT-887	C-22	TRIMMER STRIP—"C" band osc. trimmer (Part of C-19, 24)...	.40
*RC-349	C-23	CAPACITOR—2000 mmf., mica...	.30
*RT-887	C-24	TRIMMER STRIP—"B" band osc. trimmer (Part of C-19, 22)...	.40
*RC-6556	C-25	CAPACITOR—"B" band padder...	.30
*RC-304	C-26	CAPACITOR—720 mmf., silvered mica...	.30
*RC-060	C-27	CAPACITOR—.03 mfd. 600-V paper...	.25
*RC-048	C-28	CAPACITOR—.02 mfd. 600-V paper...	.30

\* Used on previous receivers.

Stock No.	Symbol	Description	List Price
*RC-023	C-29	CAPACITOR—.005 mfd. 600-V paper	\$0.25
*RC-011	C-30	CAPACITOR—.002 mfd. 600-V paper	.25
*RC-039	C-32	CAPACITOR—.01 mfd. 600-V paper..	.25
	C-33a	CAPACITOR—10 mfd. 300 V dry electrolytic	1.30
RC-5204	C-33b	CAPACITOR—15 mfd. 400 V dry electrolytic	
	C-33c	CAPACITOR—15 mfd. 400 V dry electrolytic	
*RC-191	C-34	CAPACITOR—.002 mfd. 1000-V paper	.35
*RC-039	C-35	CAPACITOR—.01 mfd. 600-V paper..	.25
*RC-252	C-36	CAPACITOR—200 mmf., mica	.30
*RC-249	C-37	CAPACITOR—220 mmf., mica	.25
*RC-327	C-38	CAPACITOR—82 mmf., compensating cap.	.25
*RQ-1259	R-1	RESISTOR—1000 ohm 1/2-W carbon	.70-5
*RQ-1243	R-2	RESISTOR—220 ohm 1/2-W carbon..	.70-5
*RQ-1283	R-3	RESISTOR—10,000 ohm 1/2-W carbon	.70-5
*RQ-1275	R-4	RESISTOR—4700 ohm 1/2-W carbon..	.70-5
*RQ-1299	R-5	RESISTOR—47,000 ohm 1/2-W carbon	.70-5
*RQ-1291	R-6	RESISTOR—22,000 ohm 1/2-W carbon	.70-5
*RQ-1339	R-7	RESISTOR—2.2 megohms 1/2-W carbon	.70-5
*RQ-1239	R-8	RESISTOR—150 ohm 1/2-W carbon...	.70-5
*RQ-1251	R-9	RESISTOR—470 ohm 1/2-W carbon...	.70-5
*RQ-1299	R-10	RESISTOR—47,000 ohm 1/2-W carbon	.70-5
*RQ-1355	R-11	RESISTOR—10 megohm 1/2-W carbon	.70-5
*RQ-1308	R-12	RESISTOR—100,000 ohm 1/2-W carbon	.70-5
*RQ-1317	R-13	RESISTOR—270,000 ohm 1/2-W carbon	.70-5
*RQ-1323	R-14	RESISTOR—470,000 ohm 1/2-W carbon	.70-5
*RQ-1295	R-15	RESISTOR—33,000 ohm 1/2-W carbon	.70-5
*RQ-1283	R-16	RESISTOR—10,000 ohm 1/2-W carbon	.70-5
*RQ-1259	R-17	RESISTOR—1000 ohm 1/2-W carbon..	.70-5
*RQ-1435	R-18	RESISTOR—200 ohm 1-W carbon...	.15
*RQ-1259	R-19	RESISTOR—1000 ohm 1/2-W carbon..	.70-5
*RQ-1265	R-20	RESISTOR—1800 ohm 1/2-W carbon..	.70-5
*RQ-1283	R-22	RESISTOR—10,000 ohm 1/2-W carbon	.70-5
*RQ-1221	R-23	RESISTOR—27 ohm 1/2-W carbon...	.70-5
*RQ-1309	R-24	RESISTOR—120,000 ohm 1/2-W carbon	.70-5
*RV-137	R-25	VOLUME CONTROL—2 meg. volume control	.95
*RQ-1311	R-26	RESISTOR—150,000 ohm 1/2-W carbon	.70-5
*RQ-1323	R-27	RESISTOR—470,000 ohm 1/2-W carbon	.70-5
*RQ-1269	R-28	RESISTOR—2700 ohm, 1/2-W carbon	.70-5
*RQ-1295	R-29	RESISTOR—30,000 ohm, 1/2-W carbon	.70-5
*RQ-685	R-30	RESISTOR—12,000 ohm 2-W carbon	.25
*RQ-1323	R-32	RESISTOR—470,000 ohm 1/2-W carbon	.70-5
*RQ-1315	R-33	RESISTOR—220,000 ohm 1/2-W carbon	.70-5
*RQ-1259	R-34	RESISTOR—1000 ohm 1/2-W carbon..	.70-5
*RQ-1299	R-35	RESISTOR—47,000 ohm 1/2-W carbon	.70-5
*RT-724	R-36, S5	TONE CONTROL—Treble tone control and power switch	1.45

Prices subject to change without notice.